

LED Zubehör  
 LED accessories

**FIELDLED EVO Leuchtenhalter, schwenkbar 150°,  
 1 Paar, für FIELDLED EVO, 150 mm breit**

<b>Artikel-Nr.:</b>	210200-22
<b>EAN:</b>	4260556625683

<b>Bestell-Nr.:</b>	210200-22
<b>Bauform:</b>	Winkel
<b>Anzahl:</b>	1 Paar
<b>Geeignet für:</b>	FIELDLED EVO Aufbau
<b>Lieferumfang:</b>	Leuchtenhalter, 2 Stück
<b>Material:</b>	Edelstahl V2A
<b>Abmessungen (mm):</b>	94 x 25 x 95 (Raummaß)
<b>Befestigung an Leuchte:</b>	Haltewinkel zur Montage an Stirnseite der Leuchte
<b>Gewicht:</b>	160 g
<b>Bruttogewicht:</b>	210 g

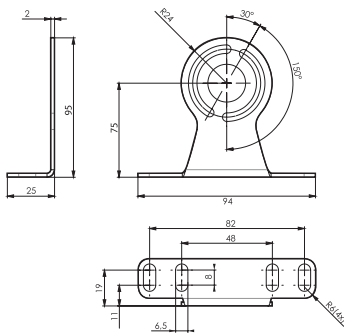



**FIELDLED EVO light holder, pivotable 150°,  
1 pair, for FIELDLED EVO, width 150 mm**

**Item number:** 210200-22  
**EAN:** 4260556625683

**Order number:** 210200-22  
**Model:** mounting bracket  
**Quantity:** 1 pair  
**Suitable for:** FIELDLED EVO Aufbau  
**Scope of delivery:** light holders, 2 pieces  
**Material:** stainless steel V2A  
**Dimensions (mm):** 94 x 25 x 95 (cubic measure)  
**Assembling:** holders for assembling at the end caps of the light  
**Weight (net):** 160 g  
**Gross weight:** 210 g

