

LED Maschinenleuchte

LED machine light

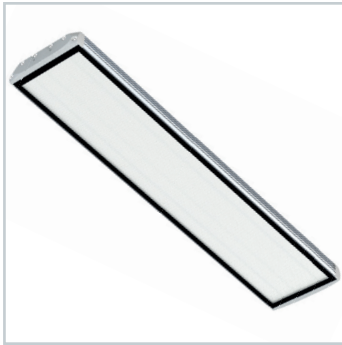

FIELDLED EVO 1040_96 Aufbau, 1040 mm, 24V DC

Artikel-Nr.: 153310-01
EAN: 4260556625539

Bestell-Nr.:	153310-01
Modell:	FIELDLED EVO 96 Aufbau
Bauform:	LED Aufbauleuchte für Maschinen
Leuchtmittel:	SMD LED
Lampenleistung:	~78 W
Lampenlichtstrom:	12000 lm
Lampenlichtausbeute:	155 lm/W
Lichtverteilung:	direkt
Lichtfarbe:	Tageslichtweiß (5200 - 5700K)
Anschlusswert Leuchte:	24V DC ± 10%
Anschluss Leuchte:	M12 Sensorstecker A-kodiert, stirnseitig
Schutzart:	IP67/IP69K
Schutzklasse:	III
Entblendung:	Mikroprismen
Abstrahlwinkel:	100°
Betriebstemperatur:	-30... +60 °C
Farbwiedergabe (Ra):	> 85
Lampenlebensdauer:	> 60.000 h
Material Gehäuse:	Aluminium
Material Abdeckung:	ESG (Sicherheitsglas), splitterfrei
Höhe [B] x Breite [C]:	30 x 96 mm
Länge [A]:	1040 mm
Gewicht:	~3450 g
Bruttogewicht:	~4250 g
Risikogruppe (DIN EN 62471):	freie Gruppe
Befestigungszubehör:	optional; 2 Schraubkanäle für M5 rückseitig
Dimmbar:	optional über Zubehör
Kennzeichnung:	CE, UKCA, ETL Listed (5003526)
Gefertigt in:	Deutschland

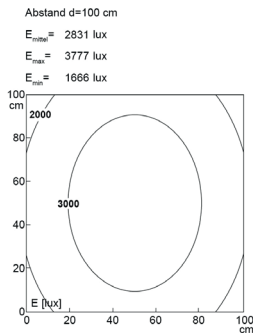

Abstand [m]	Kegeldurchmesser [m]	Beleuchtungsstärke [lx]
0.5	1.06	E(0°) 1790
	0.94	E(C90) 3685
		E(CD) 3445
1.0	2.11	E(0°) 4438
	1.88	E(C90) 721
		E(CD) 661
1.5	3.17	E(0°) 1972
	2.82	E(C90) 321
		E(CD) 383
2.0	4.23	E(0°) 1109
	3.76	E(C90) 189
		E(CD) 215
2.5	5.29	E(0°) 710
	4.70	E(C90) 115
		E(CD) 138
3.0	6.34	E(0°) 493
	5.63	E(C90) 80
		E(CD) 96

Abstand [m] Kegeldurchmesser [m] Beleuchtungsstärke [lx]

— C0 - C180 (Halbstrahlwinkel: 86.4°)
 — C90 - C270 (Halbstrahlwinkel: 93.2°)

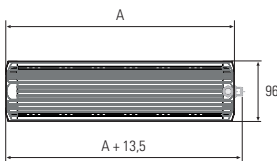

Lampenlebensdauer in Betriebsstunden (L80/B10)

LED Maschinenleuchte
LED machine light

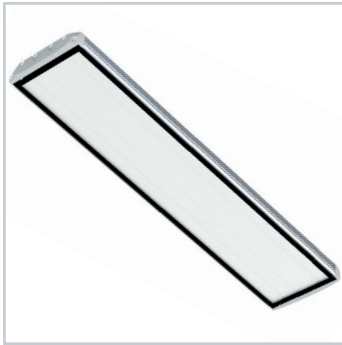

FIELDLED EVO 1040_96 Aufbau, 1040 mm, 24V DC

Item number: 153310-01
EAN: 4260556625539

Order number:	153310-01
Model:	FIELDLED EVO 96 Aufbau
Type:	LED surface-mounted luminaire for machines
Illuminant:	SMD LED
Power consumption:	~78 W
Lamp luminous flux:	12000 lm
Lamp luminous efficiency:	155 lm/W
Light distribution:	direct
Light colour:	daylight white (5200 - 5700K)
Connected load:	24V DC ± 10%
Connection:	M12 sensor connector, A-type encoded, front-end
Degree of protection:	IP67/IP69K
Class of protection:	III
Glare-free	microprism
Beam angle (optics):	100°
Operating temperature:	-30... +60 °C
Colour rendering (Ra):	> 85
Lamps lifetime:	> 60,000 h
Housing material:	aluminium
Cover material:	ESG (toughened safety glass), shatterproof
Height [B] x Width [C]:	30 x 96 mm
Length [A]:	1040 mm
Weight (net):	~3450 g
Gross weight:	~4250 g
Risk group (DIN EN 62471):	free group
Mounting accessories:	optional; two continuous screw channels for metric screws with thread M5 on the reverse
Dimmable:	via optional accessory
Marking:	CE, UKCA, ETL Listed (5003526)
Made in:	Germany

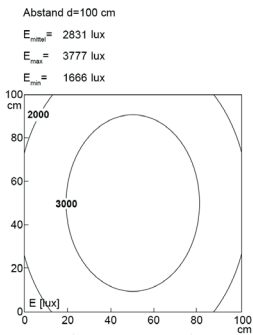

Abstand [m]	Kegeldurchmesser [m]	Beleuchtungsstärke [lx]
0.5	1.06	E(0°) 17750
	0.94	E(C90) 46.6° 3885
		E(CD) 43.2° 3445
1.0	2.11	E(0°) 4438
	1.88	E(C90) 46.6° 721
		E(CD) 43.2° 661
1.5	3.17	E(0°) 1972
	2.82	E(C90) 46.6° 321
		E(CD) 43.2° 383
2.0	4.23	E(0°) 1109
	3.76	E(C90) 46.6° 189
		E(CD) 43.2° 215
2.5	5.29	E(0°) 710
	4.70	E(C90) 46.6° 115
		E(CD) 43.2° 138
3.0	6.34	E(0°) 493
	5.63	E(C90) 46.6° 80
		E(CD) 43.2° 96

Abstand [m] Kegeldurchmesser [m] Beleuchtungsstärke [lx]

— C0 - C180 (Halbstrahlwinkel: 86.4°)
— C90 - C270 (Halbstrahlwinkel: 93.2°)

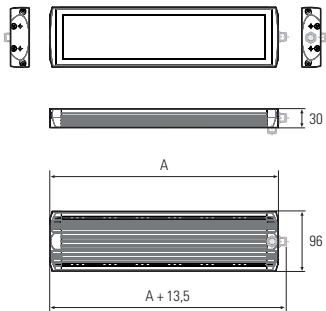

Lamps lifetime in operation hours (L80/B10)